

### esave SLC-DC



### esave SLC-AC



## Description

The Street Light Controller is a compact device which can be easily embedded in any LED street light and used with all major electronic control equipment. It is already equipped with wireless communication, making it the ideal solution with no need to worry about time-consuming routing of data cables and saving on installation costs. With esave Street Light Controller your lighting system gains intelligence, helping reduce energy consumption and keeping maintenance costs down to the absolute minimum.

## Compatible sensors

- esave PIR5 ST sensor
- esave PIR5 HS sensor
- esave PIR Pilz sensor
- Legrand wattstopper FDP-301
- Tridonic PSensor SSI 31 2xPIR 8DP DG
- esave LightRadar
- esave Brightness sensor

## Features

- Fully configurable dim profiles by time, week-days and/or sensor inputs
- Automatically organizing wireless mesh network
- AES encrypted wireless communication
- Wirelessly configurable and updateable
- Automatic adjustment of daylight and standard saving time
- Automatic wireless distribution of date/time
- Support for most used industry standard dimming interface types (Analog 0-10V; PWM; DALI and DALI-2)
- Optional support for motion sensors, radar, twilight sensor and LED temperature
- Integrated temperature sensor
- Energy usage determination
- Configurable distribution of twilight sensor value and motion detection value
- AC and DC supply voltage support
- Low power consumption
- Support for active monitoring and protection of LED temperature
- Configurable LED luminous flux compensation over lifetime (LFC)
- Custom sensors and extensions possible
- Easy to use software for on-site configuration and controlling
- Optional integration into a web based management and control application with on-site gateway devices
- GPS-Option to synchronize the time and automatically determine the position

### Wiring

#### DALI LED Driver

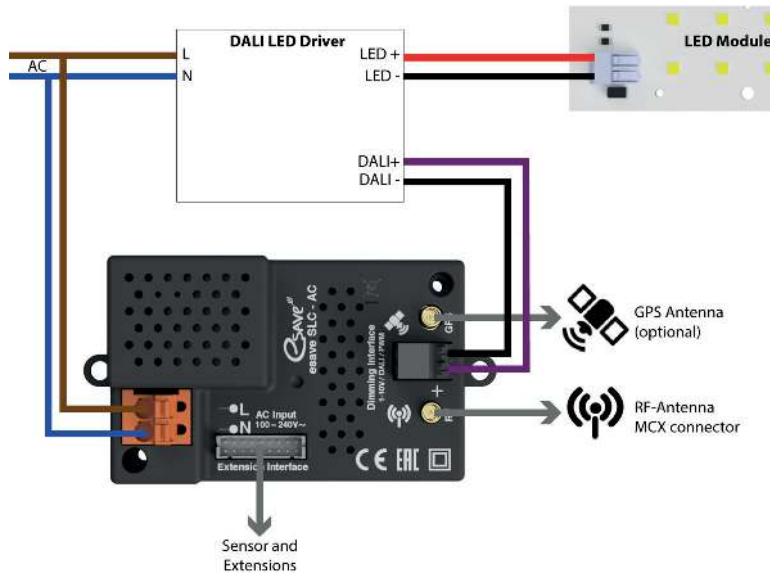

#### DALI LED Driver with DC 24V output

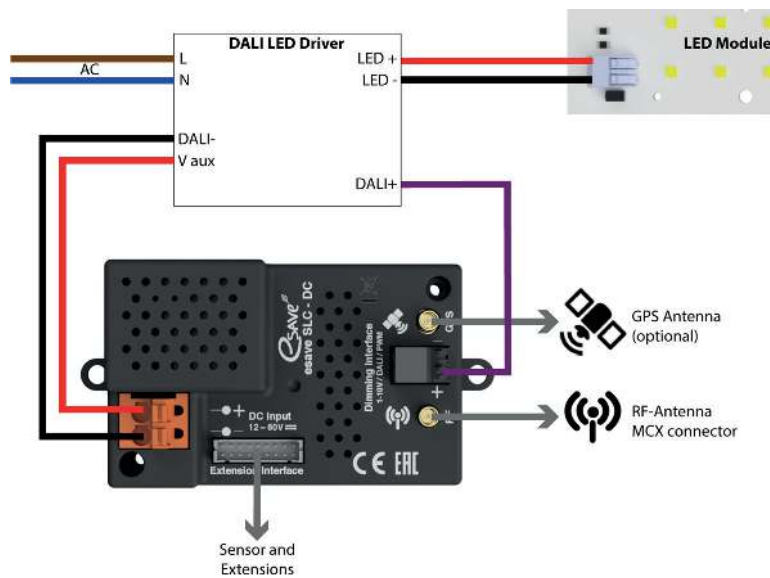

#### Analog output LED Driver

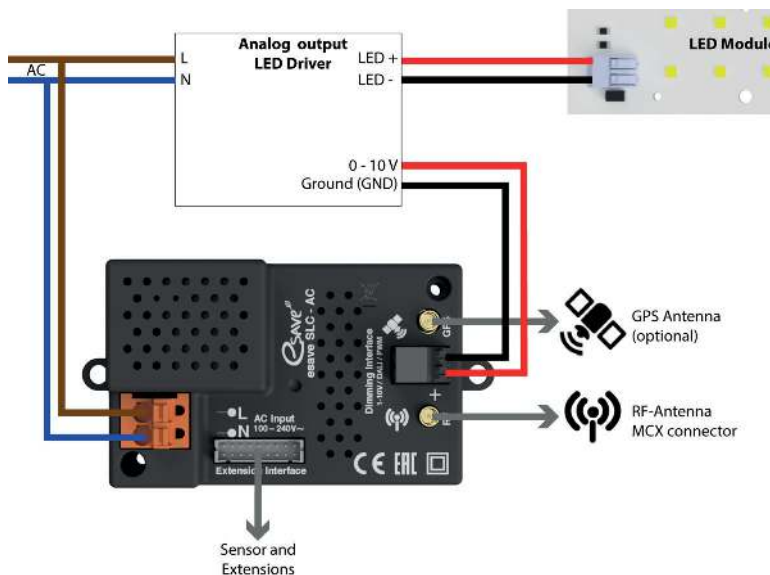

### Dimensions

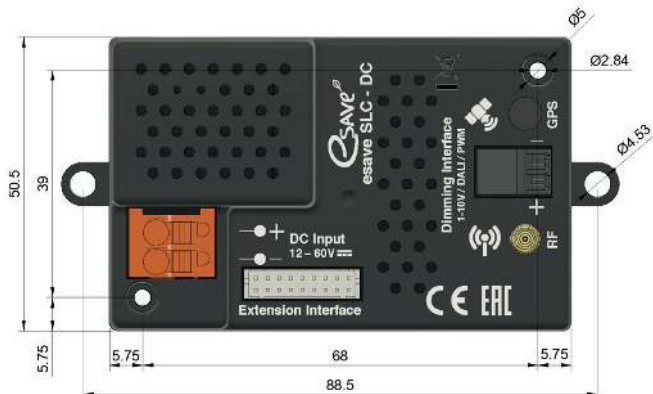

### Sensor and Extension Interface

Interface Pin	Name	Description
1	V_EXT12	Extension power supply (+12V)
2	-	Reserved
3	MOT	Motion detector signal
4	LED_TEMP	LED Temperature sensor signal
5	GND	Ground
6	V_EXT3	Extension power supply (+3.2V)
7	BRIGHT	Brightness sensor signal
8 - 15	-	Reserved
16	SWITCH_OUT	Extension Switch output: Open collector output
17	-	Reserved
18	V_EXT3	Extension power supply (+3.2V)

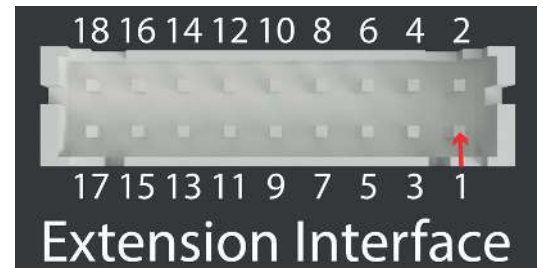

The esave SLC modules can optionally be equipped with the sensor mentioned on the first page. The following pins are used for the different sensors.

For reliable operation, please use only sensors supplied or approved by esave ag.

#### Motion Detector

- Pin 3 = Motion detector Signal (MOT)
- Pin 5 = Ground (GND)
- Pin 6 or Pin 18 = +3.2V (V\_EXT3)

#### Brightness Sensor (Twilight)

- Pin 6 or Pin 18 = +3.2V (V\_EXT3)
- Pin 7 = Brightness sensor input (BRIGHT)

#### LED Temperature Sensor

- Pin 4 = LED Temp. sensor input (LED\_Temp)
- Pin 5 = Ground (GND)

#### Extension Switch Output

- Pin 1 = +12V (V\_EXT12)
- Pin 16 = Extension Switch output: Open collector output (SWITCH\_OUT)

### Installation

The esave SLC modules are designed to mount on the inside of a metal or plastic housing. Therefore, the controller can be screwed onto a carrier plate via the two fastening lugs or the diagonally arranged fastening holes.

#### Fastening lugs (M4 screws)

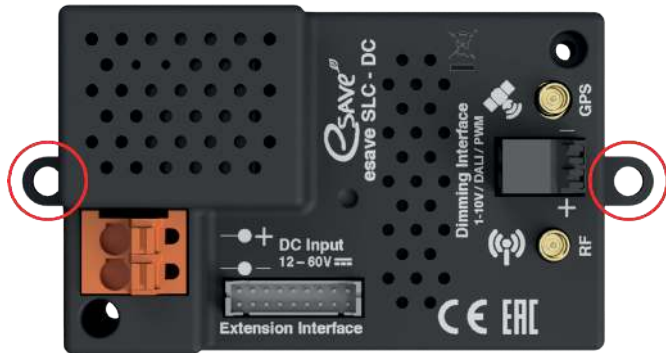

#### Fastening holes (M2.5 screws)

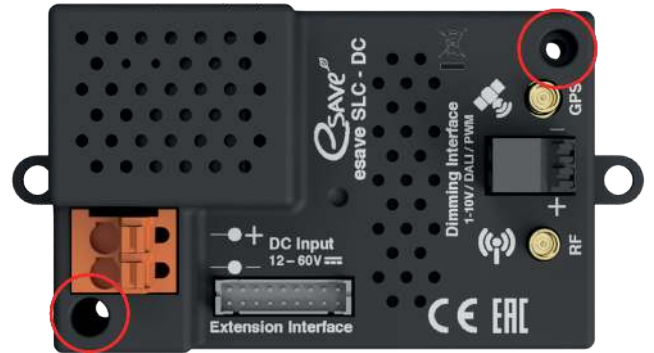

### RF Antenna

The antenna position is relevant for a good radio performance. If the luminaire housing is made of metal, than it is recommended to mount the antenna on top of the luminaire housing. Connect the antenna with a MCX connector to the controller.

#### Street Light

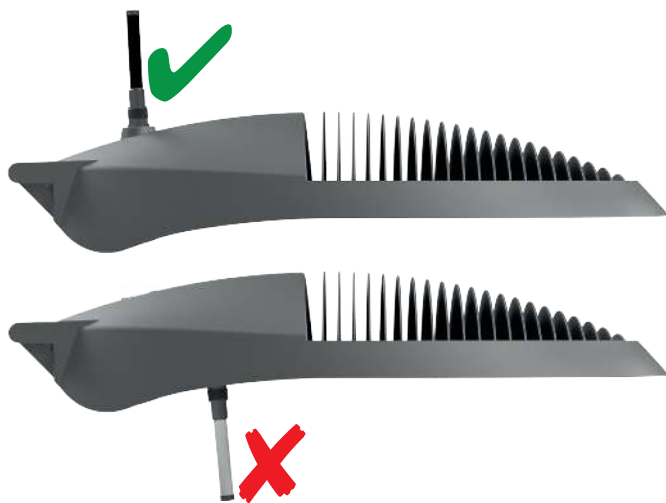

#### Metallic box



#### Plastic box without RF shielding

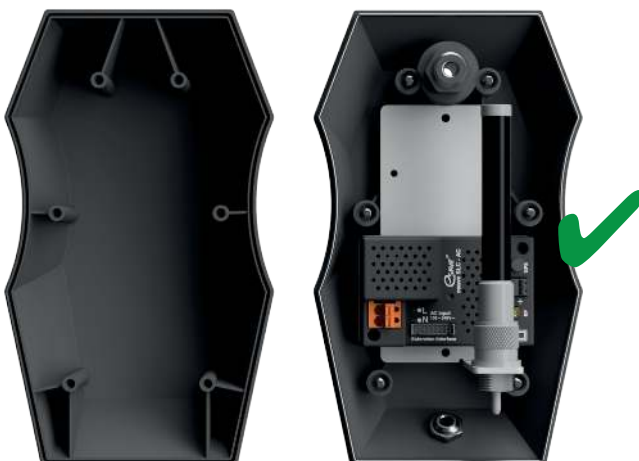

## Maximum ratings

Parameter	Type	Sym	Min	Max	Unit
Supply Voltage	SLC-AC SLC-AC GPS	$V_{in}$		240	V AC
	SLC-DC SLC-DC GPS		0	60	V DC
Operating temp.	SLC-AC SLC-AC GPS	$T_A$	-25	+80	°C
Operating temp.	SLC-DC SLC-DC GPS		-25	+85	°C
Storage temp.	any	$T_S$	-40	90	°C
Surge / burst input voltage immunity (all connectors)	any	$V_{ps}$		2.0	kV
Motion sensor input voltage (Pin 3)	any	$V_{mot}$	-0.2	3.3	V
Brightness (Twilight) sensor input voltage (Pin 7)	any	$V_{bright}$	-0.2	5.0	V
3.2V Power supply output current (Pin 6 & 18)	any	$I_{ext3}$		35	mA
12V Power supply output current (Pin 1)	any	$I_{ext12}$		40	mA
Switch output max. voltage (Pin 16)	any	$V_{sw}$	-0.2	12	V
Switch output sink current (Pin 16)	any	$I_{sw}$		100	mA
Dim interface output current (Actively limited in DALI and PWM output mode) $I_{out A}$ = Analog $I_{out D}$ = DALI $I_{out P}$ = PWM	any	$I_{out A}$	0	25	mA
		$I_{out D}$	0	18	
		$I_{out P}$	0	2	

## Extension / Sensor connector operating characteristics

Parameter	Pin	Sym	Min	Typ	Max	Unit
Extension power output voltage 3.2V	6 18	$V_{ext3}$	3.0	3.2	3.3	V
Extension power output voltage 12V	1	$V_{ext12}$		12		v
Motion detector inactive high signal	3	$V_{mot H}$	2.5		3.2	V
Motion detector active low signal	3	$V_{mot L}$	-0.2		0.5	V

## Operating characteristics

Parameter	Type	Sym	Min	Typ	Max	Unit
Supply Voltage Range	SLC-AC SLC-AC GPS	$V_{in}$	100		240	V AC
	SLC-DC SLC-DC GPS		12		60	V DC
Power usage $I_{out} = 0$ mA No sensor or ext. connected  *1 $V_{Sup} = 230$ V AC *2 $V_{Sup} = 12$ V DC *3 $V_{Sup} = 24$ V DC *4 $V_{Sup} = 40$ V DC	SLC-AC	$P_{op}^{*1}$		0.43		W
	SLC-AC GPS			0.68		
	SLC-DC	$P_{op}^{*2}$		0.22		
	SLC-DC GPS			0.48		
	SLC-DC	$P_{op}^{*3}$		0.25		
	SLC-DC GPS			0.52		
	SLC-DC	$P_{op}^{*4}$		0.25		
SLC-DC GPS			0.54			
Dim interface output voltage $I_{out} = 0$ mA Output mode: $V_{out A} =$ Analog $V_{out D} =$ DALI $V_{out P} =$ PWM	any	$V_{out A}$	0.0		10.2	V
		$V_{out D Low}$	0.0	0.1	0.2	
		$V_{out D High}$	11.0	11.5	12.5	
		$V_{out P Low}$	0.0	0.1	0.2	
		$V_{out P High}$	11.0	11.5	12.5	

## Wireless and GPS characteristics

Parameter	Type	Sym	Min	Typ	Max	Unit
RF frequency range (center frequency)	any	$f_w$	2.420		2.480	GHz
RF nominal output power	any			4.5	8	dBm
Receiver sensitivity	any			-97	-92	dBm
GPS First time to fix (cold start)	SLC-AC GPS SLC-DC GPS			50		s
GPS accuracy	SLC-AC GPS SLC-DC GPS			2.5		m

## Approvals

Category	Declaration / Certificates
CE conformity	CE compliant
Hazardous substances	RoHS compliant: Restriction of Hazardous Substance Directive
Housing flame resistance	UL Recognized Flame Class Rating: UL 94 V-0
Electromagnetic compatibility (EMC / ERM)	<ul style="list-style-type: none"> <li>EN 300 328 V2.1.1 (2016-11)</li> <li>EN 301 489-1 V2.2.0:2017-03</li> <li>EN 301 489-17 V3.2.0:2017-03</li> <li>EN 61000-6-2:2005</li> </ul>
Safety	<ul style="list-style-type: none"> <li>EN 62368-1:2014+AC:2015</li> </ul>